

[1] The Autonomous Mill: Utilizing Digital Twins to Optimize the Pulp & Paper Mill of the Future

Brad S. Carlberg, P.E.

Senior Control Systems Engineer

BSC Engineering Hoodspout, WA 98548

+1 (251) 454-1200 [brad.carlberg@bsc-engineering.com](mailto:brad.carlberg@bsc-engineering.com)

## KEYWORDS

Autonomous Mill, Digital Twin, Advanced Process Control (APC), Model-Based Predictive Control (MPC), modelling, optimize, automation, control loops, P&ID, virtual plant, basis weight, black liquor, bleach plant, causticizer, consistency, digester, dilution factor, evaporators, freeness, green liquor, headbox, Kappa Number, lime kiln, paper, pulp, recovery boiler, refiner, screening, sootblower, washing, white liquor, woodyard..

## ABSTRACT

This paper will describe the Autonomous Mill of the future as a mill that benefits from the use of Digital Twins utilizing a process model coupled with a control model of the real-time control system to allow the Autonomous Mill to “run itself” with little or no human intervention.

This paper will then give an overview of the unit operations and equipment common to pulp and paper mills and conclude with several examples of specific opportunities where control systems optimization through Advanced Process Control (APC) and Model-Based Predictive Control (MPC) can increase production; reduce costs, and autonomously operate the mill of the future.

The pulp and paper mill is often divided into six main “islands” of automation: raw material receiving and preparation (the woodyard), the pulp mill, the powerhouse, the paper mill, converting and finishing, and effluent treatment. Each of these islands presents their own, unique set of unit operations; but, perhaps not surprisingly, you can see similar unit operations in various industries besides pulp and paper. For example, the powerhouse equipment, besides the main difference being that the fuel is “black liquor”, the equipment can be found in any other industrial power plant. In the paper machine “island”, the use of cascaded variable-speed drives to control the paper sheet tension is also seen in the draw line of a steel, textile, or fiber mill. And, as a final example, the effluent treatment facility of the paper mill has many of the same equipment you will find in a municipal water/wastewater plant.

Several examples of specific control systems optimization included for each of these “islands” include chemical savings in the lime kiln and causticizing, pulping, screening and refining, washing, and bleaching processes of the pulp mill; energy savings in recovery boiler sootblowing and the lime kiln, pulp stock preparation including cleaning and refining and the paper pressing and drying sections of the paper mill; and the environmental savings involved in effluent treatment and recycling water.

Lessons learned:

1. What is an Autonomous Mill?
2. What is a Digital Twin?
3. understand the equipment and the processes in a pulp and paper mill
4. understand the similarities to other industries
5. understand specific areas where control system optimization can decrease costs and/or increase production

## INTRODUCTION

This paper will give the reader a roadmap to how to arrive at the autonomous paper mill.

This paper will approach it by picking an area (say the digester or evaporators for example) and show how, from equipment, instrumentation, and advanced control, the equipment are operated at a typical mill now.

The paper will go on to show how advanced control has optimized the mill areas and how a dynamic model has been used to design, checkout the control logic and train operators.

The next logical step (for a model) is to be used to assist when instruments fail by providing a digital twin of the instrumented signal (soft sensor).

This capability allows the plant area to move toward continuous and error free automation.

Once continuous automation is achieved for one mill area, then operators are freed to observe more and intervene less, in the same manner that pilots are more dependent on automatic control of their aircraft than a generation ago.

Thus, can be achieved in a single mill area, then eventually the entire mill.

For the near future there will need to be operators in the mill; but by utilizing advanced control coupled with digital twin technology, mill operators will trend toward less direct intervention to a more supervisory role as trust is gained in the ability of the mill to become more autonomous.

## DEFINITION OF THE AUTONOMOUS MILL

A popular definition:	acting independently or having the freedom to do so. synonyms: self-governing independent sovereign free self-ruling self-determining autarchic self-sufficient
Our Definition:	The Autonomous Mill is “a mill that runs itself with little or no human intervention” utilizing a Digital Twin coupling the process model with the control model. [6]

The development of the Autonomous Mill is following the same path as that of the autonomous auto. First, smart sensors and instruments were required to reliably collect data. Next came secure and robust communications methods to move the data from the mill floor to a control computer, and back. And finally comes the software and human expertise to combine equipment data with data pulled from process computers (DCS) and data mined from a mill’s enterprise- wide computer (ERP) to “navigate” the best path for production and profits. [7]

## DIGITAL TWIN STANDARDS



ISO TECHNICAL REPORT TR 24464 1st Edition, November 2020 [2]

ISO 23247 [3]  
Automation Systems And Integration — Digital Twin Framework For Manufacturing  
Part 1: Overview and general principles  
Part 2: Reference architecture  
Part 3: Digital representation of manufacturing elements  
Part 4: Information exchange  
Part 5: [Digital thread for digital twin](#)  
Part 6: [Digital twin composition](#)



International  
Electrotechnical  
Commission

ISO/IEC TR 30172 ED1: Digital Twin - Use cases [4]

ISO/IEC 30173 ED1: Digital Twin - Concepts and terminology [5]



AK-POSITION Digital twin in process automation 2022-02-01 WG  
1.3 Information management and tools



The Authority in Digital Twin™ . A global ecosystem comprising  
industry, government, and academia.

The development of the Autonomous Mill is following the same path as that of the autonomous auto. First, smart sensors and instruments were required to reliably collect data. Next came secure and robust communications methods to move the data from the mill floor to a control computer, and back. And finally comes the software and human expertise to combine equipment data with data pulled from process computers (DCS) and data mined from a mill's enterprise-wide computer (ERP) to “navigate” the best path for production and profits. [7]

## DEFINITION OF THE DIGITAL TWIN

The Digital Twin is a virtual plant, a dynamic model that contains the process, mechanical and electrical/control design information in one place. [8]

Utilizing a dynamic model of the process, design deficiencies can be corrected. Utilizing an advanced control loop system for optimized operation of various areas, difficulties of traditional PID control are overcome by similar utilization of a model predictive controller. First, the ability to create and embed knowledge into precompiled objects that represent common equipment; second, to have design decisions communicated to all engineering disciplines through a database; and third, the ability to communicate via OPC (OLE for Process Control) to any control system. The virtual plant has now changed how the process is designed.

Model Predictive Control (MPC) provides an additional tool to improve the control of critical processes where PID or rule based expert control is not well suited to the application. MPC is often able to reduce process variability beyond the best performance that could be obtained with PID or expert system control methods. MPC can manage applications where there are delays in the process response to actuator changes or multiple interactions between process variables. In particular, MPC can optimize the control of processes that exhibit an integrating-type response in combination with transport delays or variable interaction. This type of response is particularly difficult to control.

The virtual plant concept unites the engineering disciplines and enables process and control designs to be tested prior to start-up. Model Predictive Control (MPC) has been shown to provide additional production and improved operability.

A Digital Twin is an up-to-date representation, a model, of an actual physical asset in operation. It reflects the current asset condition and includes relevant historical data about the asset. Digital twins can be used to evaluate the current condition of the asset, and more importantly, predict future behavior, refine the control, or optimize operation. [9]

A Digital Twin consists of several key elements and features:

- A virtual, dynamic model of the process.
- The model is initialized based on the original design and is updated during procurement (vendor data), construction (as-builts), precommissioning, commissioning, start-up, and operations to stay aligned with the physical asset.
- The physical asset is instrumented with sensors which can capture its current operational state. “A Digital Twin allows analysis of data and system monitoring in a way that dramatically improves operations, preventing downtime, reducing maintenance costs, and providing data that can be used to streamline operations throughout the lifecycle of the asset.”

Digital Twins require process models that are dynamic and real-time. The characteristics of process models can be summarized in three categories: [10]

Steady-State models are used for plant equipment sizing and process design. Inputs to these models are pressures, temperatures, flows, and compositions; and outputs are equipment sizing and process optimizations. These models can be very complex (or high fidelity), but a steady-state model does not simulate transitions between process states including time delays, deadtimes, or mass holdups.

Dynamic models use equipment sizes and specifications for inputs with outputs of pressures, temperatures, levels, flows, and compositions. They are time based and resolve transitions between process states. Outputs to the model are affected by the inputs along with the time delays and deadtimes of the model. Holdups and mass are calculated with the result of a dynamic material, energy, and momentum balance.

Real-time models are a sub-set of dynamic process models. A real-time model must converge or resolve at a fast enough cycle to allow updates to the control loops and operator console identical to the real plant.

#### CREATING DYNAMIC PROCESS MODELS

The tasks of creating dynamic process models for the individual areas of a world-class Kraft pulp mill can be challenging; the ability to import and export the actual control system configuration to-and-from the Digital Twin allows not only a comprehensive check-out of the process models, but also verification of the process control strategy and the application programming composed to implement it. [11]

The operator's workstation uses the same operator-interface graphics as in the real plant. At the workstation, the operator has full use of the same screens that he will use in the real plant. The Digital Twin software and hardware to run the DCS configuration, again exactly as it will be run in the field; and the virtual signals upon which the emulated DCS configuration code acts are generated by the process models.

#### DEVELOPMENT OF THE PROCESS MODELS

The Digital Twin uses first principles equations to calculate mass, energy, and momentum balances across multi-component systems. Appropriately programmed, models can predict the operating characteristics of the process and track variables of interest. One particularly valuable feature of the modeling software is its ability to interface directly with most distributed control systems. An Object Library is a repository for a group of pre-programmed objects.

#### STAGING THE DCS AND THE DIGITAL TWIN [11]

##### Step 1 - Mapping of DCS/Digital Twin inputs and outputs (I/O Mapping)

On the Digital Twin side, the first step executed is the mapping into the system of all DCS inputs and outputs. In this step, each I/O device in the process model and the matching entities in the DCS configuration must be aligned. The product of this activity is called the "Cross-Reference Database". The model developer accomplishes this activity, as the onus is on him to match the DCS system, not the other way around. The modeler needs only support from a DCS technician in obtaining an appropriate DCS configuration Backup. At this stage, the DCS configuration does not have to be a highly developed one. With his Cross-Reference Database assembled, the model developer could appear at staging perhaps three days before the finish of the conventional DCS contractor's FAT, for a final pre-check of process model-DCS communications.

##### Step 2 - Verification of the individual control loops; verification of configuration coding

The model developer must have the support of a DCS technician, for adjustment of control parameters. including all features such as group starts and sequencing from the DCS side, individual control loops were tested, by trying to start the area. Motor start/stops also were tested and controllers pre-tuned. modeling corrections or changes take a more detailed look at the control philosophy, interlock strategies.

##### Step 3 - Verification of the EPC operating procedures and final validation of the process models

Verification of the EPC operating procedures and final validation identified mistakes in DCS configuration coding; modeling errors or suggested changes; control strategy errors or suggested changes in control philosophy A DCS configuration which could start the "virtual mill" was considered highly likely to be a configuration which would start the real mill. The virtual mill (in essence a dynamic process model, an area DCS control configuration and an array of supporting hardware and software) was at this point ready to be applied to operator training.

Once the dynamic process model, or Virtual Process Plant, is built in the Digital Twin Software, the planned process plant behavior is analyzed over a range of pulp quality parameters, production rates, and

operational settings and constraints. The Virtual Paper mill helped discover dynamic system behavior problems, including process control issues. [12]

THE DATA REQUIRED FOR THE MODEL BUILDING INCLUDES:

- Process flow diagrams (PFDs)
- Piping and instrumentation diagrams (P&IDs)
- Process design criteria
- Process description
- Process control philosophy
- Mechanical equipment list
- mill plans and raw material delivery schedules
- Process quality data
- Equipment elevations and layouts
- Pump and control valve data sheets, and other equipment specifications
- Piping line lengths and resistances (orthogonal drawings)

NEXT STEPS

The next step is to run the Digital Twin, just as a real plant can be run, through startup sequences, production rate changes, ore changes, etc. to determine how the plant will behave, dynamically, during such changes.

The models were already highly developed and were ‘run’ to simulate process operation in faster-than-real time; where the engineer discovered process problems in the Virtual Process Plant, would confer with the process engineer(s) to help investigate problem & then correct the problem in the real plant.

With the Digital Twin and the Process Model, coupled with the DCS and the Control Model; the behavior of the Autonomous Mill can be analyzed over a range of production rates, operational settings, and constraints; key process design assumptions and decisions, could be made clear and the Autonomous Mill can be optimized.

ADVANTAGES OF MPC

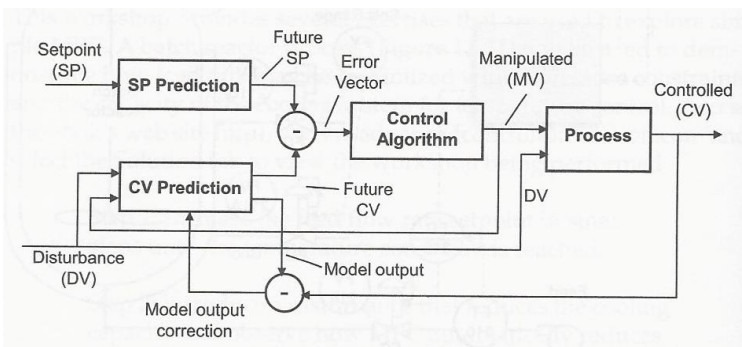

Figure 1 shows an MPC controller for a process with two inputs and one output in a form that allows one to see the analogy to a typical feedback control loop. The process has a manipulated variable MV (the output) and a disturbance variable DV that acts on a controlled variable CV (input).

A simple MPC controller used in this configuration has three basic components:

- process model that predicts processor output
- a future trajectory of the set point
- a control algorithm for computing the control action based on error

Figure 1 - MPC Controller Operation Principle [25]

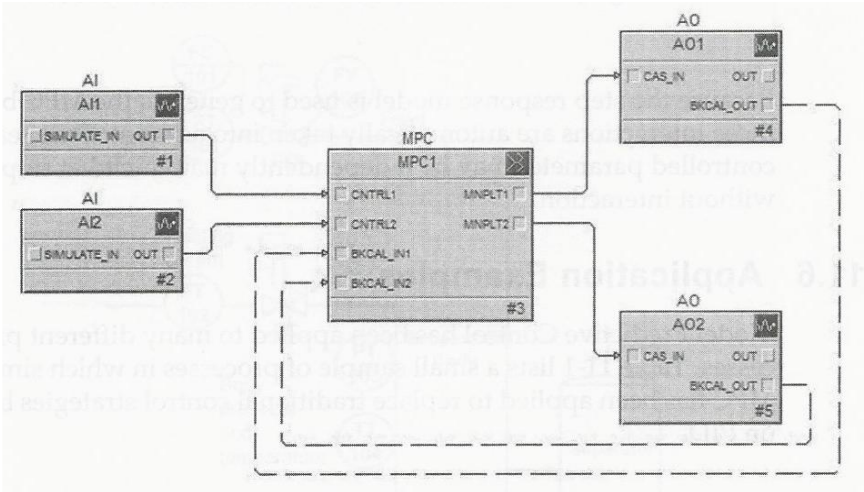

Figure 2 - MPC Implementation for Interactive Processes [25]

Because the impact of each manipulated input parameter on each controlled output grammar is identified by the step response model used in MPC blocked generation the MPC block automatic compensates for any interactions. [25] The MCC block and its connections to associated input and output blocks are shown in figure 2

## OPTIMIZATION OPPORTUNITIES IN THE PULP AND PAPER MILL

Multitudes of careers have been spent understanding and refining the pulp and paper industry and textbooks and technical papers too numerous to list have been written about the various processes and equipment in a pulp and paper mill.

There are many opportunities for optimization, either involving energy savings, chemical saving, and/or increases in production rate, of the processes throughout the pulp and paper mill. Several examples will be described in the paragraphs to follow.

### RECOVERY BOILER AUTOMATION [15]

The Recovery boiler can be optimized to adjust for the continual variability in Black Liquor BTU value and compensate for changes in boiler load. When the effects of liquor BTU and boiler load variations are eliminated, all parameters associated with the recovery process becomes more stable and the boiler can typically be operated with a higher throughput, better efficiency, improved green liquor reduction, minimized fouling, and reduced emissions. When compared to a traditional control strategy, this system can provide the following benefits to mill recovery operations:

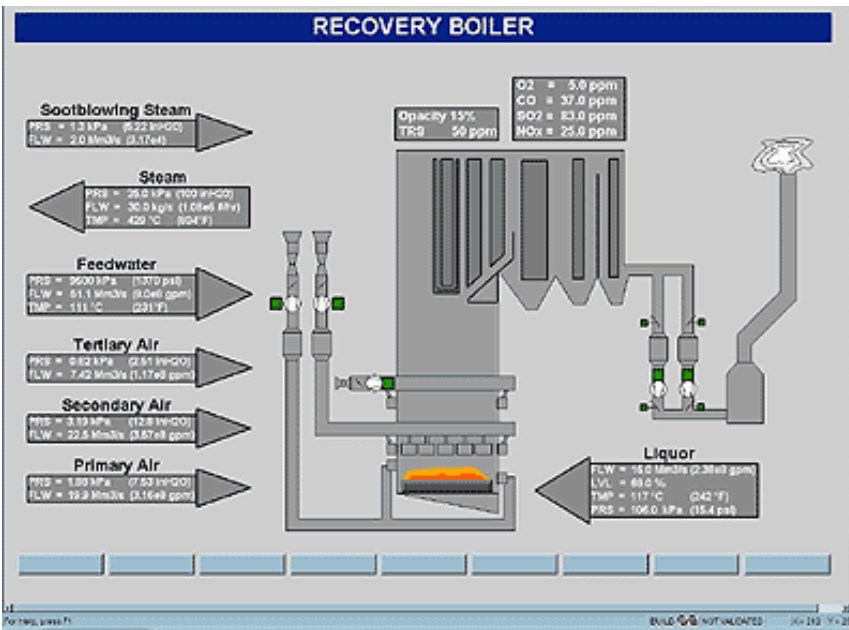

- 5-15% increase in black liquor throughput
- 1-2% increase in thermal efficiency
- Improved reduction efficiency
- Reduced water wash frequency
- Improved environmental compliance
- Reduced variability in all process parameters
- Automatic control virtually at all times
- Consistent boiler operation throughout all shifts

Figure 3- Recovery Boiler DCS Operator Graphic

POWERHOUSE PLANT MASTER

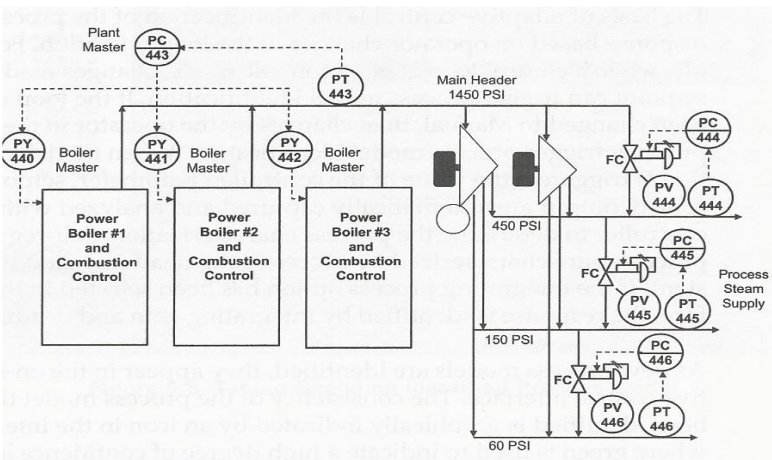

The process gain associated with a loop can be impacted by the number of process units that are available to act on the PID output. An example of this is Powerhouse Plant Master control, where the number of swing boilers on-line impacts the process gain associated with the main header pressure control that is provided by the plant master controller as shown in Figure 4.

By applying adaptive control, the plant master controller tuning can be modified to automatically compensate for the number of swing boilers on-line.

Figure 4- Powerhouse Plant Master [25]

## RECOVERY BOILER SOOTBLOWING



Figure 5 – Recovery Boiler Sootblower

As was mentioned in the first section, the Kraft Recovery Boiler utilizes steam sootblowers (usually around fifty per boiler) to blow fly ash in the combustion gases off of the boiler tubes.

Without the sootblowers, particulate would build up on the tubes effectively insulating them preventing heat transfer to the water and thereby reducing the steam output from the boiler and lowering the boiler efficiency.

To level the steam usage to the boiler the individual sootblowers are scheduled so that they operate in a predefined sequence.

Optimization of these sequences can involve using “smart sootblowing” [16] based upon furnace draft pressures and temperatures which would signal when to blow certain regions of the tubes. [17]

For example, if the temperature rises in a particular region, that would say that the tubes are becoming covered with soot and it would run the sootblowers in that region.

- Uses high-pressure steam to blow soot off of boiler tubes to improve heat transfer between furnace gases and boiler water
- Sequence the individual sootblower operation for optimal steam usage
- Low Temp & High Diff Press signal which sections to blow

## BLACK LIQUOR EVAPORATORS

The purpose of the black liquor evaporators is to concentrate the weak black liquor from the pulp washing process at around 15% solids to around 60% solids that will burn effectively in the recovery boiler.

The evaporators can be either a packed single-column or multi-effect (up to seven).

To decrease the evaporation temperature, the multi-effect units operate at a vacuum.

The process can be optimized by using pressure and temperature differential to signal tube fouling that would cause a decreased heat transfer rate and a lower vacuum and automatically start a boilout of the evaporators to clean the fouling.

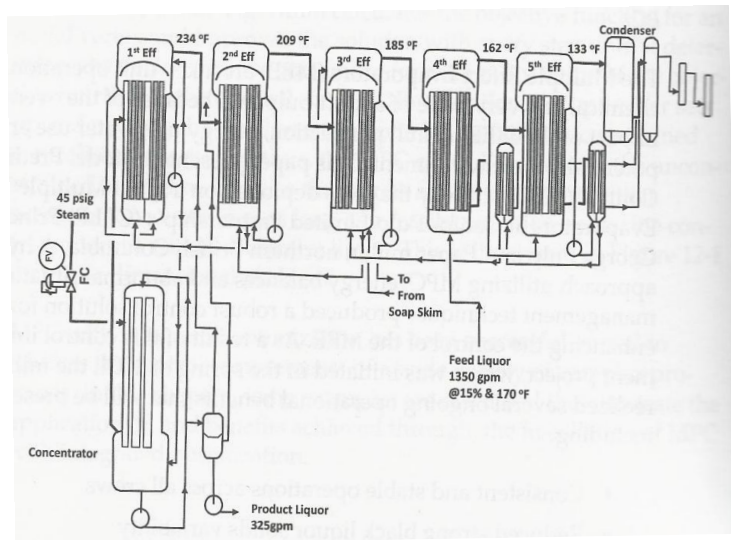

Figure 6- Multiple Effect Evaporator Process [25]

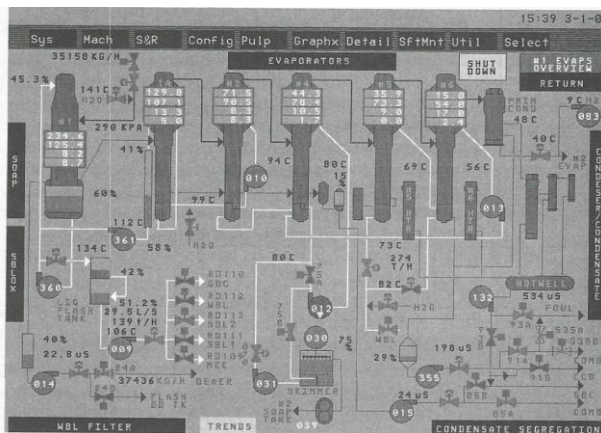

Figure 7- Multiple Effect Evaporator DCS Operator Graphic [25]

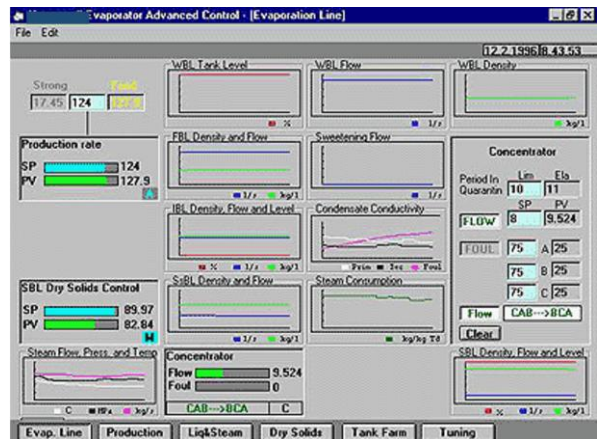

Figure 8- Multiple Effect Evaporator DCS Operator Graphic [25]

## RECAUSTICIZING

In causticizing area of the pulp mill green liquor is reacted with lime to form the white liquor used in the wood chip digesting (cooking) process. Traditionally, conductivity was used as a variable to measure the reaction completeness. With new nuclear instruments the exact chemical constituents in the white liquor can be determined to better gauge the reaction completeness. Since the causticizing process is by nature a process with a long lag time and not a good candidate for traditional PID control; a new optimization technique involving using Model-Based Predictive Control (MPC) [18], can tune the process more tightly which would yield a more consistent white liquor product.

Long Deadtime means Good case for Multivariable Predictive Controller

CV – Conductivity

MV – Green Liquor & Lime feeder ASDs

DV – White Liquor Production Rate

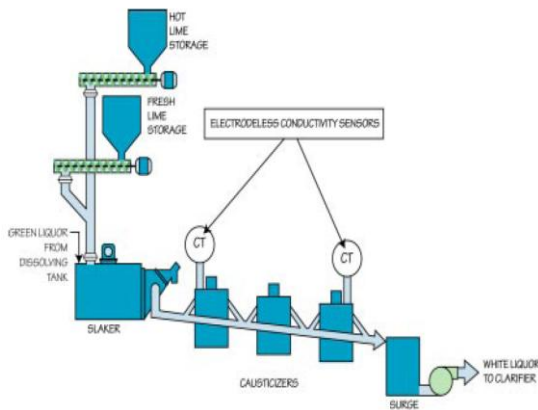

Figure 9- Slaker & Causticizers

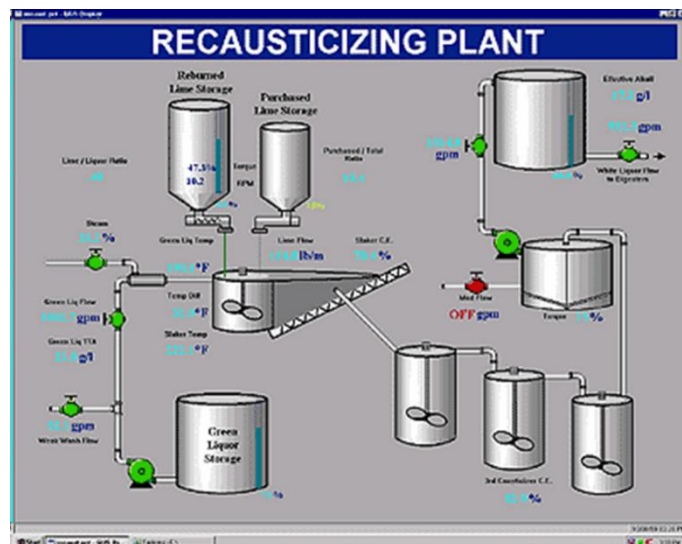

Figure 10- Slaker & Causticizers DCS Operator Graphic

## BATCH AND CONTINUOUS DIGESTERS

The pulp digesting (cooking) process uses either/or batch or continuous digesters. Either way, the principle is the same; the wood chips and the cooking chemicals are added to the digester and under pressure and at an elevated temperature from the steam addition, the wood chips are cooked (really “exploded”) for sixty to ninety minutes. The pulp stock slurry exits the digester at a consistency of 6% and the resulting pulp fibers are close to the state they need to be in to make the paper.

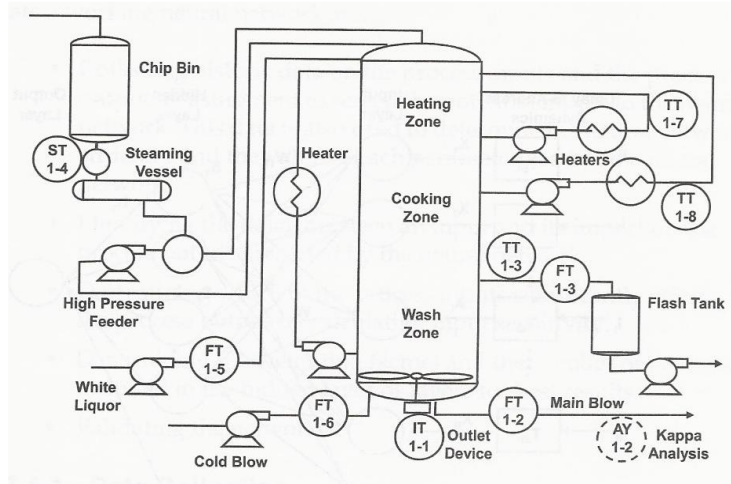

Figure 11- Continuous Digester Process [25]

The chip meter speed sets the digester production rate. The Kappa number can be measured using an online analyzer or by analyzing the grab sample in the lab. The delay associated with each input that is reflected in the Kappa number is automatically determined by doing cross correlation between the process inputs and the Kappa number. [25]

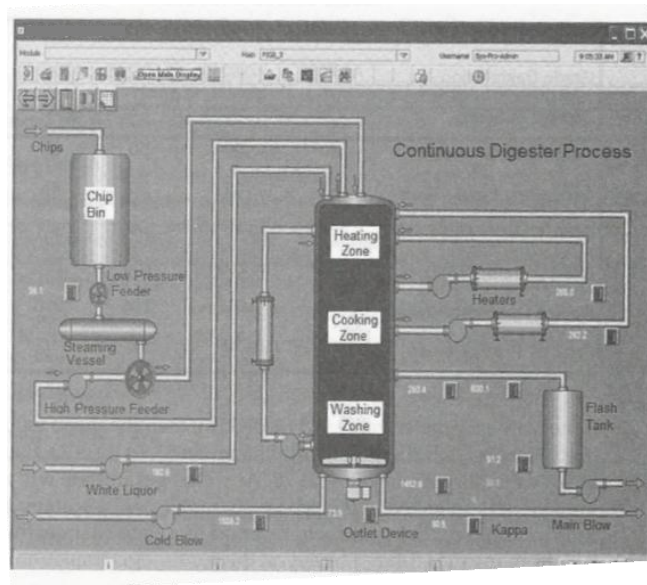

Figure 12- Continuous Digester DCS Operator Graphic [25]

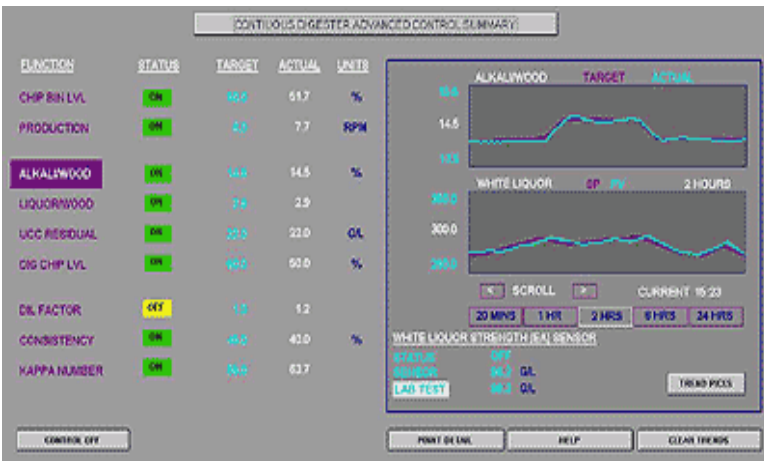

Figure 13- Continuous Digester Advanced Control Summary

- Kappa Number is the amount of delignification of the pulp fiber
- For example, brown board will have a higher Kappa Number than bleached pulp
- White Liquor Analyzer to sense residual chemical
- Kappa Analyzer to sense fiber delignification

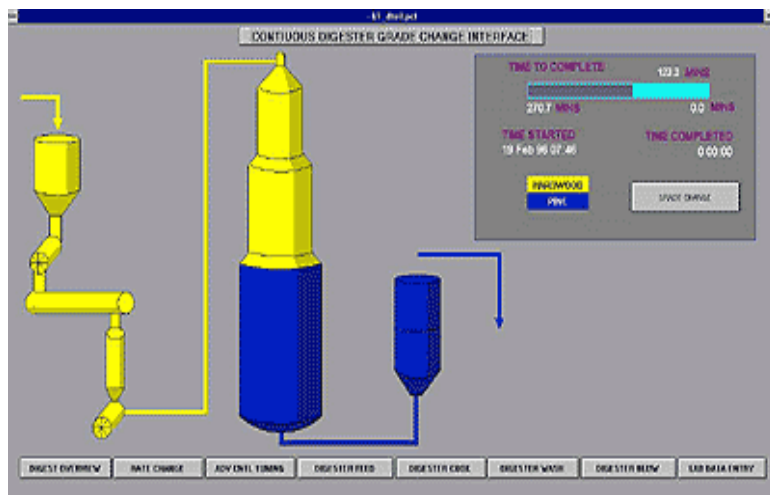

Figure 14- Continuous Digester Grade Change

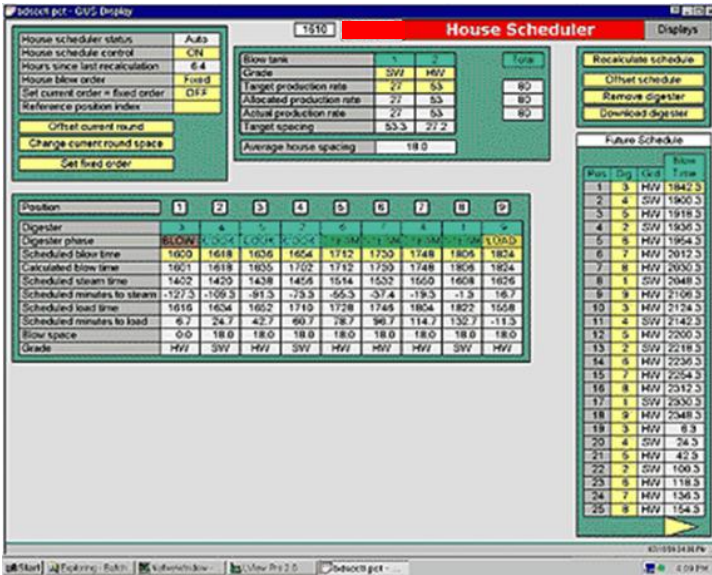

Figure 15- Batch Digester Overview [19]

- Batch Scheduling - Steam Leveling smoothes boiler operation
- Chip Qualities – uniform moisture
- Batch digesters- liquor analyzer
- Better Kappa control
- Reduce white liquor usage
- Batch digesters- Kappa analyzer
- Better Kappa control

The optimization here can involve energy savings by increasing throughput and scheduling the batches so that steam consumption is leveled so that spikes cause fluctuations in the boiler demand.

Also, online freeness (a measure of the cooking completeness) analyzers can close the control loop to more accurately determine when the cook is complete.

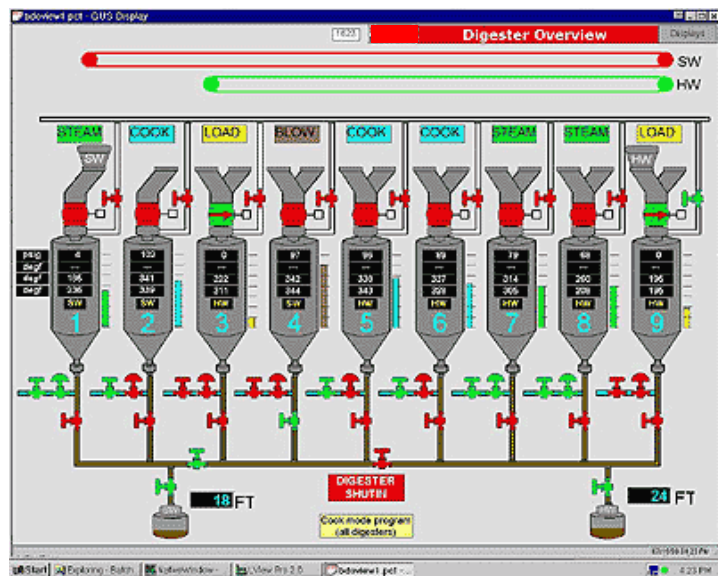

Figure 16- Batch Digester House Scheduler [19]

## SCREENING AND REFINING

Screening and refining are used to get a more uniform pulp stock. The screen, which is a piece of equipment with a rotating, cylindrical basket with either slots or holes, lets the optimally sized pulp fibers pass through but centrifugally removes knots, uncooked or undercooked fiber bundles that can be recycled back to the digester for additional cooking. The refiner, which is a piece of equipment with two rotating, rough-surfaced plates, is used to cut or defibrillate the wood fibers giving more uniform pulp stock

## WASHING

The digested, screened, and perhaps refined pulp stock, although uniform in fiber size, is still very dirty with all the organic and inorganic byproducts from the digesting process, known as weak black liquor at around 15% solids. The

dark color comes primarily from the lignin which is the “glue” that binds the wood fibers and gives the wood its strength and rigidity. There are also a lot of residual cooking inorganic chemicals that can be reused in the digesting process.

The brown stock washers usually consist of multiple (three), countercurrent (which means pulp stock comes one direction and clean wash water comes from the opposite direction) stages. [20] Fresh make-up wash water is added on the cleanest pulp at the latter stages to wash the pulp stock, but the recycled weak liquor wash water is added on the dirtiest pulp at the earlier stages. A common optimization technique is to use Dilution Factor Washing based on pounds of wash water to pounds of wood fiber (the optimal ratio is about 1.0) to minimize overwashing that would use more water that would subsequently need to be evaporated to get the black liquor to the magic number of 74% for burning in the recovery boiler.

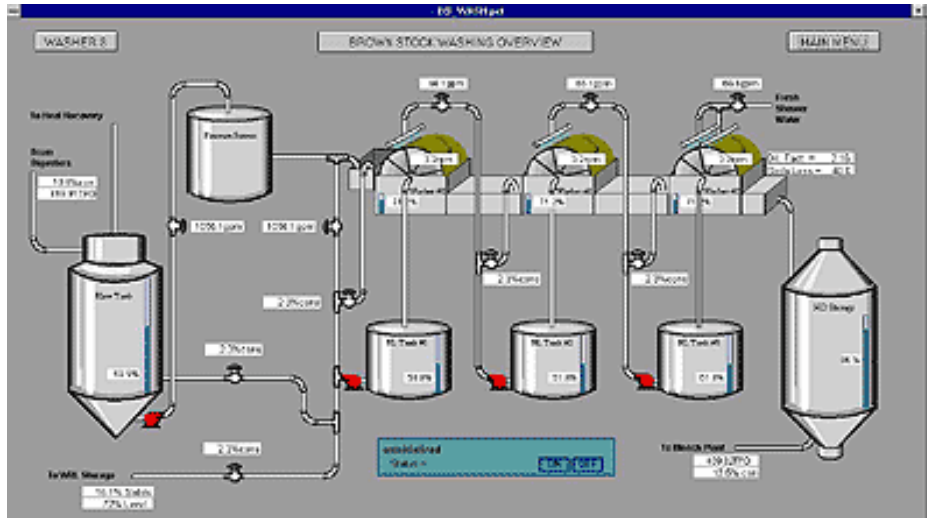

- An Optimum Dilution Factor of 1.0 means that the Lbs wash water equals the lbs pulp stock
- Less wash water reduces the load on the evaporators i.e. steam usage

Figure 17- Brown Stock Washer Overview

## BLEACHING

The decision whether to bleach the pulp is based on the final product of the paper mill. If the product is cardboard or paper sacks, bleaching is probably unnecessary. But if the product is writing paper, paper towels, tissue, diapers, etc. then the pulp will need to be bleached. The bleach plant usually consists of multiple (three to five) stage washers interspersed between bleach towers. [22] [23] Typically, bleaching chemicals are liquid or gaseous chlorine, chlorine dioxide, sodium hydroxide, sodium hypochlorite, hydrogen peroxide, liquid or gaseous oxygen, and liquid or gaseous ozone. These bleaching towers allow the resident time (usually one to three hours per tower) for the bleaching chemicals to brighten and whiten the pulp.

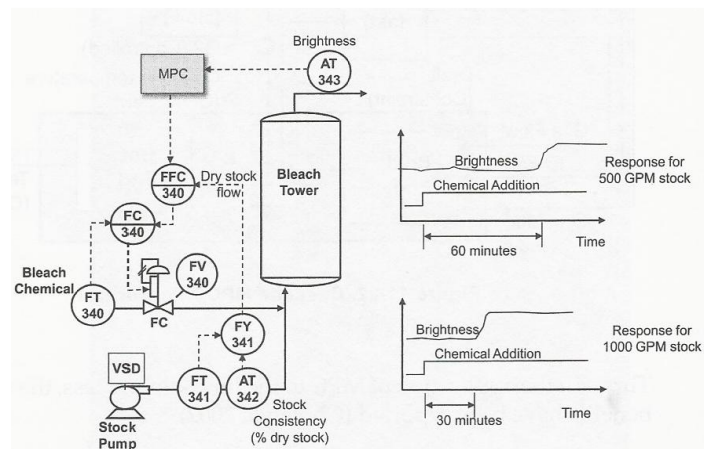
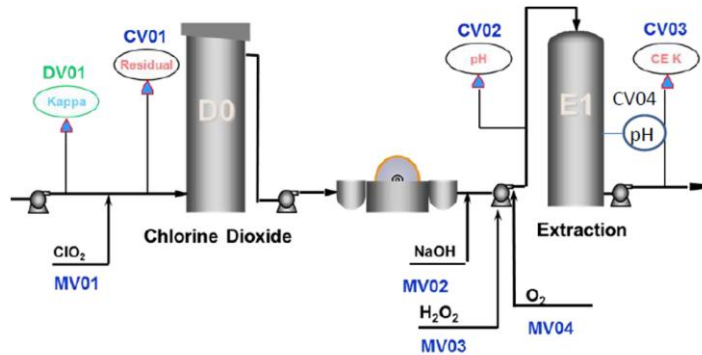

Figure 18- Impact of Throughput – Bleach Tower Example [25]

The predominant area for savings in the bleach plant is to optimize the chemical usage by utilizing techniques something like KAPPA Factor bleaching and stock tracking throughout the bleaching stages to apply bleaching chemical based on a precise ratio of pounds of effective chlorine to the pounds of fiber.

As with the causticizer, the bleaching process is by nature a process with a long lag time and not a good candidate for traditional PID control; a new optimization technique involving using Model-Based Predictive Control (MPC) [24], can tune the process more tightly which would yield a more consistently bleached pulp.



Again, Long Deadtime means a good case for Multivariable Predictive Controller [21]

Figure 19- Elements of Advanced Control [22]

D0 Stage [22]

- DV01 – Kappa
- CV01 – ClO<sub>2</sub> Residual
- CV02 – Inlet pH
- CV03 – CE Kappa
- CV04 – Terminal pH

E<sub>OP</sub> Stage

- MV01 – ClO<sub>2</sub> flow
- MV02 – NaOH flow
- MV03 – H<sub>2</sub>O<sub>2</sub> flow
- MV04 – O<sub>2</sub> flow

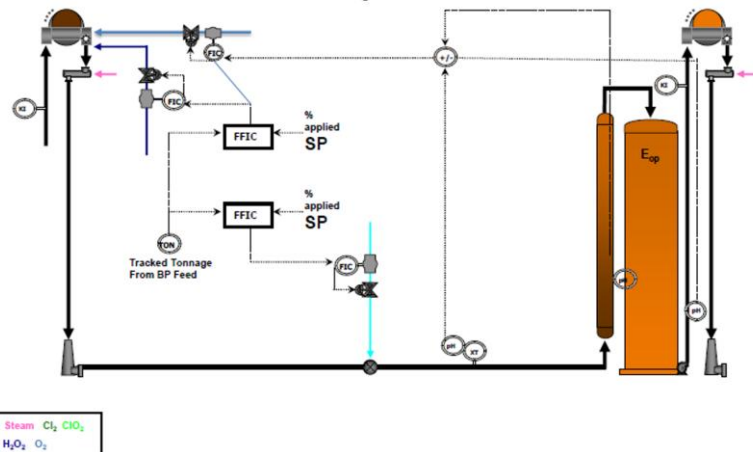

Figure 20- E<sub>OP</sub> Control [22]

What are the components? [22]

- Tonnage
- Incoming pH
- Caustic Dosage
- Caustic to TEC Ratio

## LIME KILN

The lime kiln is a large (15 ft diameter by 200 ft long), rotating cylinder used to calcinate the byproduct of the causticizing process [26], the lime mud, to convert it back to the lime that can be added in the causticizer.

The predominant area for savings is the energy (gas burned in the lime kiln) savings by optimizing the lime mud moisture content and the temperature of the calcined lime exiting the kiln.



Figure 21- Lime Kiln Process

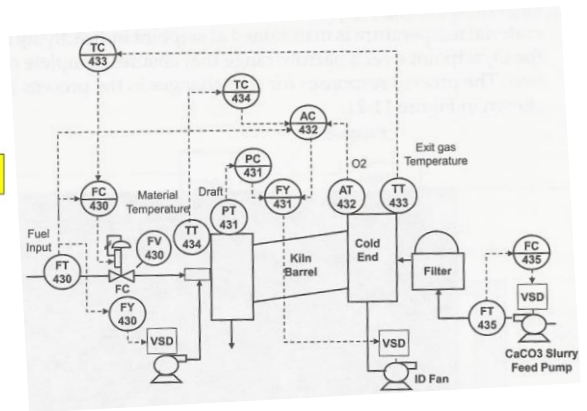

Figure 22- Lime Kiln Process P&ID [25]

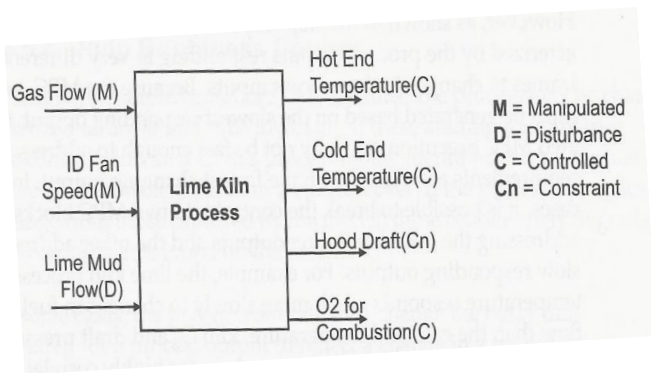

Figure 23- Lime Kiln MPC [25]

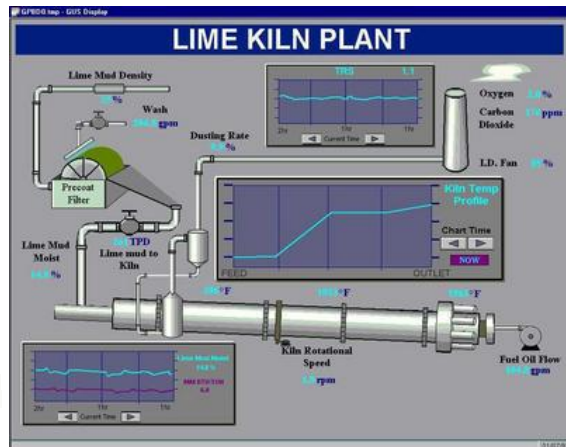

Figure 24- Lime Kiln DCS Operator Graphic

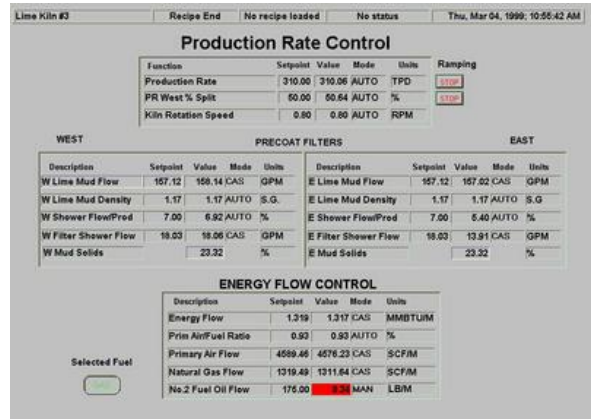

Figure 25- Lime Kiln Lime Kiln Advanced Control Summary

Figure 26- Lime Kiln Production Rate Control

As with the causticizer and bleach plant, the Lime kiln process is by nature a process with a long lag time and not a good candidate for traditional PID control; a new optimization technique involving using Model-Based Predictive Control (MPC) [25], can tune the process more tightly which would yield a more efficient combustion process.

- Long Deadtime means Good case for Multivariable Predictive Controller
- CV – Temps
- MV – ID Fan ASD
- DV – Production Rate

## CHEMI-THERMO-MECHANICAL-PULP (CTMP)

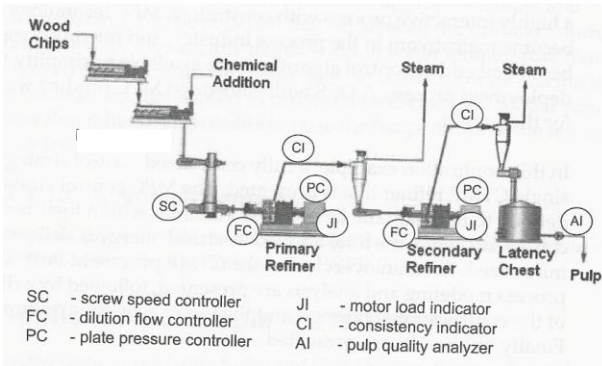

MVs	CVs
Plug screw speed	Primary motor load
Primary plate pressure	Secondary motor load
Secondary plate pressure	Canadian Standard Freeness (CSF)
Primary dilution flows (DE & TE)	Primary blow line consistency
Secondary dilution flows (DE & TE)	Secondary blow line consistency

Figure 27- CMTF Refiner [25]

In order to produce high quality Chemi-Thermo-Mechanical-Pulp (CTMP) the refining process must be under tight control. Closed loop control of a mechanical refining system is one of the most complex and challenging control problems in a pulp mill. The process is inherently multivariable and exhibits strong interactions. [25]

There is a direct relationship between the specific energy (kWh per ton) and the pulp quality (freeness). This relationship is constant provided the furnished composition (wood chip mixture, bulk density, moisture, etc.) is constant for a given production rate.

MPC control strategy new line Definition of the control objectives and priorities is a key step in defining the MPC control strategy. The main objectives of the control strategy are:

- Attenuate wood chip density variations
- control pulp quality (freeness)
- Minimize total applied electrical load
- minimize refiner motor loads
- Control blow line consistency
- maximize production rate

The primary objectives of the MPC controllers to minimize refiner motor loads while maintaining the freeness within operator specified targets.

The mainline refiners consume a significant amount of electrical energy to reduce wood chips to pulp. In fact, CTMP refiners are the single biggest consumer of electrical energy in the mill and hence present the largest opportunity for energy and cost reductions.

Based on historical data, a process energy consumption model was derived. A fully centralized control strategy based on MPC using online linear programming and optimization was developed.

The benefits of using the MPC based control strategy resulted in significant savings and a significant reduction in freeness variability.

## PULP STOCK PREPARATION, CLEANING, REFINING, AND BLENDING

This is the area where the pulping ends and the papermaking begins. The “art of papermaking” is in the final cleaning to remove any remaining contaminants, in the “tickle” refining to “brush” the fibers to optimize fiber bonding in the paper sheet, in the blending of different pulp species (hardwood and softwood), filler, additives, to achieve the optimum paper optical, physiochemical, strength, structural, and surface properties.

## PAPER PAPERMAKING, PRESSING AND DRYING SECTIONS OF THE PAPER MILL

After all the preparation of the pulp it is stored in the machine chest. From there, the fan pump pumps the pulp stock to the headbox from which the pulp stock slurry is “laid down” on the fourdrinier wire along the entire width (sometimes over 300 inches wide) of the machine via the “slice” out of the headbox. The primary control variables in papermaking are the basis weight [27], moisture, and caliper (or thickness). [28]

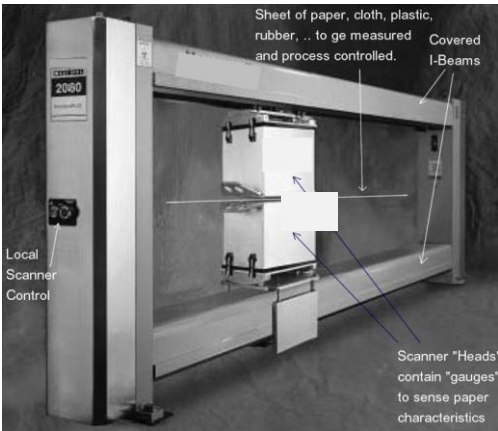

Figure 28- One Brand of Scanner



Figure 29- Another Brand of Scanner

A typical paper machine can be as long as a football field. As in the pulp mill where the majority of the processes remove the pulping byproducts; the majority of the paper machine removes the water from the paper in first the forming section, followed by the press section, and, finally, the dryer section. [29]



Figure 30- Paper Machine Dryers

The main area for savings again are those of energy savings in the dryer where steam is used to heat the “dryer cans” to heat the paper sheet as it passes over them on its way down to the “dry end” of the paper machine.

- Paper sheet rolls over the steam-heated dryer cylinders to evaporate moisture
- Optimize Steam Usage to save energy costs

Recently, the use of video cameras placed at strategic points along the paper machine has been very effectively used to alert the operators of events that can cause a paper sheet break. With this information, the operator can avoid an actual sheet break significantly decreasing production downtime. [30]

Use of cascaded and coupled, variable frequency drives controlling the various rollers in the fourdrinier wire, press, and dryer sections can more tightly regulate the tension (rush and drag) of the paper sheet mitigating undue stresses that could cause a paper sheet break.

### PRODUCTION RATE CONTROL

Use of Production Rate control will enable the Autonomous Mill to achieve optimal performance. [31]

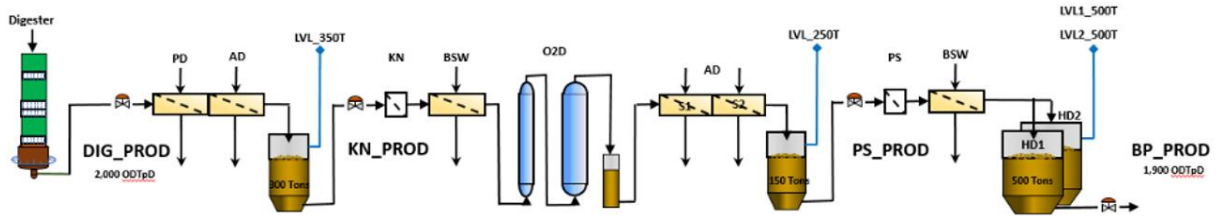

Figure 31- Production Rate Control MPC [31]

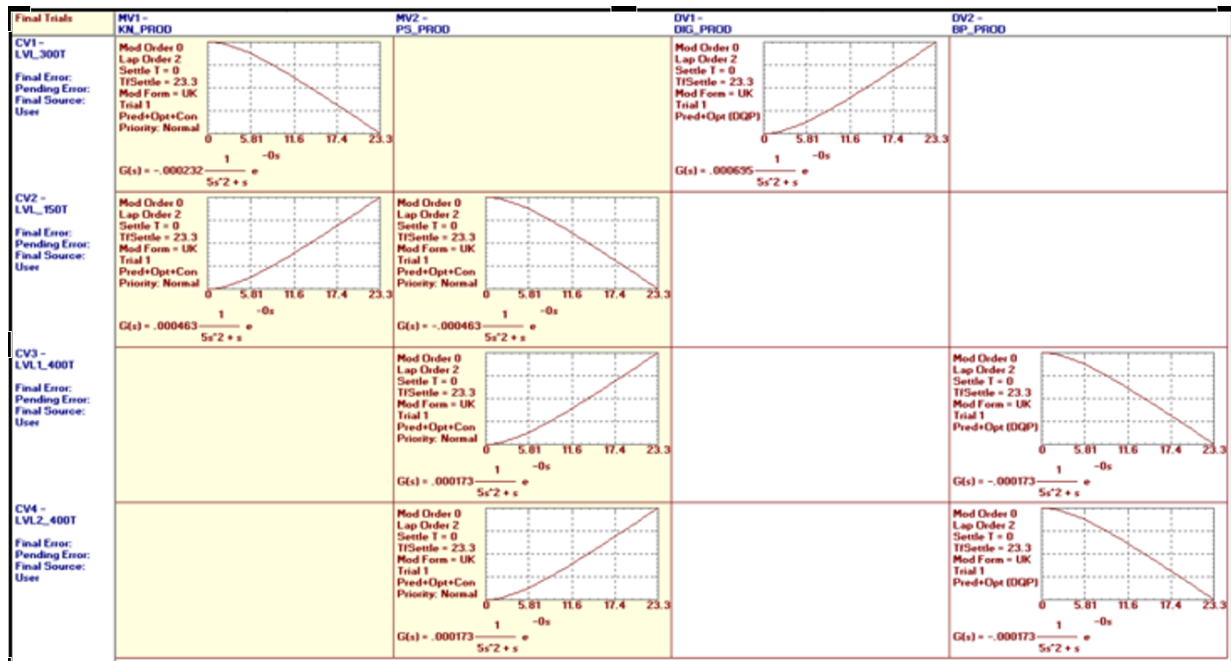

Figure 32- Production Rate Control MPC Model Identifier [31]

## CONCLUSIONS

The Autonomous Mill of the future is a pulp & paper mill that benefits from the use of Digital Twins utilizing a Process Model coupled with a Control Model of the real-time Control System to allow the Autonomous Mill to “run itself” with little or no human intervention.

This paper is merely an overview of the unit operations and equipment common to a pulp and paper mill; innumerable books and careers have been spent describing and learning these aspects of the control of these processes that I have endeavored to tell you about in these pages. Hopefully, you now can find your way around the six main “islands” of automation of any pulp and paper mill:

- raw material receiving and preparation (the woodyard)
- the pulp mill
- the powerhouse
- the paper mill
- converting and finishing
- effluent treatment

Use of Production Rate control will enable the Autonomous Mill to achieve optimal performance.

After reading this paper you now have a better understanding of the equipment and the processes in a pulp and paper mill, you can see the similarities to other industries, and you have an idea of several specific areas where control system optimization, Advanced Process Control (APC), and Model-Based Predictive Control (MPC) can increase production, decrease costs, and autonomously operate the mill of the future.

## ACKNOWLEDGEMENTS

I must acknowledge a several people without whose help throughout my life and career I would not have been able to gain the necessary experience in pulp and paper mills to write this paper.

To John Lavigne, ISA Pulp and Paper Industry Division member and ISA Fellow and the author of “An Introduction to Paper Industry Instrumentation” [13], for writing the book I read when I was new graduate Mechanical Engineer fresh out of school.

To Gary Smook, British Columbia Institute of Technology instructor and author of the “Handbook for Pulp and Paper Technologists” [14], for developing the 14-week course taught after work at H.A. Simons Ltd offices in Vancouver.

To Matt McGarry, my coworker from H.A.Simons Ltd in Vancouver, who allowed me to “pick his brain” about IDEAS Simulation & later about Digital Twins.

To Greg McMillan, ISA Fellow, who allowed me to “pick his brain” about mimic, DeltaV, & modelling, and for being a Fellow Evaluator for Fellow Nominees.

To Steve and Rick Van Fleet, my supervisors (and friends) and two of the brightest pulp and paper minds I have ever met, for giving me the opportunity to work with and learn from as we optimized several mills east of the Mississippi.

And finally, saving the best for last, to my Dad, Gary, for teaching me about pulp and paper for my third-grade science project, and for spending his entire career with the same pulp and paper manufacturing company which allowed me to be given five summer jobs in the mill to pay for my college education and learn how pulp and paper mill is actually operated.

## ABOUT THE AUTHOR

Brad. S. Carlberg, P.E. received his Bachelor of Science degree in Mechanical Engineering from Washington State University in Pullman, WA in February of 1984 & is a licensed Professional Control Systems Engineer (in Alabama & Washington) with over thirty-nine years' experience in Process Engineering and Process Control Engineering specifically with Distributed Control Systems (DCS'), Programmable Logic Controllers (PLC's), and Human Machine Interfaces (HMI's) combining extensive experience with both Hardware and Software Design, Programming & Configuration, Implementation, Startup, & Commissioning, including Advanced Continuous and Batch Control Programming. Designed, implemented, commissioned forty-seven DCS/PLC/HMI and Advanced Control (APC) automation projects over four continents (N & S America, Hong Kong, U.A.E, & South Korea) and specifically twenty-five pulp and paper mills & twenty-two other (oil&gas, waterwater, food) industrial manufacturing facilities.

Brad is an FAA-Licensed Private Pilot (Single Engine Land - SEL) since 2008, a 47-year distance runner & sub-3:20 Marathoner, an American Sailing Association (ASA) & Canadian Yachting Association (CYA) certified Sailor (sailing for 54 years), and a 50-year NAUI-Licensed SCUBA Diver. Although Brad doesn't play a musical instrument, he is a passionate jazz & blues aficionado – test his knowledge of jazz & blues!



## TABLE OF FIGURES

Figure 1 - MPC Controller Operation Principle [25].....	6
Figure 2 - MPC Implementation for Interactive Processes [25] .....	7
Figure 3- Recovery Boiler DCS Operator Graphic.....	8
Figure 4- Powerhouse Plant Master [25] .....	8
Figure 5 – Recovery Boiler Sootblower .....	9
Figure 6- Multiple Effect Evaporator Process [25].....	10
Figure 7- Multiple Effect Evaporator DCS Operator Graphic [25] .....	10
Figure 8- Multiple Effect Evaporator DCS Operator Graphic [25] .....	10
Figure 9- Slaker & Causticizers .....	11
Figure 10- Slaker & Causticizers DCS Operator Graphic .....	11
Figure 11- Continuous Digester Process [25].....	12
Figure 12- Continuous Digester DCS Operator Graphic [25] .....	12
Figure 13- Continuous Digester Advanced Control Summary .....	13
Figure 14- Continuous Digester Grade Change .....	13
Figure 15- Batch Digester Overview [19] .....	14
Figure 16- Batch Digester House Scheduler [19].....	14
Figure 17- Brown Stock Washer Overview.....	15
Figure 18- Impact of Throughput – Bleach Tower Example [25] .....	15
Figure 19- Elements of Advanced Control [22] .....	16
Figure 20- E <sub>OP</sub> Control [22].....	16
Figure 21- Lime Kiln Process.....	17
Figure 22- Lime Kiln Process P&ID [25].....	17
Figure 23- Lime Kiln MPC [25].....	17
Figure 24- Lime Kiln DCS Operator Graphic .....	17
Figure 25- Lime Kiln Lime Kiln Advanced Control Summary .....	18
Figure 26- Lime Kiln Production Rate Control .....	18
Figure 27- CMTP Refiner [25].....	19
Figure 28- One Brand of Scanner.....	20
Figure 29- Another Brand of Scanner.....	20
Figure 30- Paper Machine Dryers.....	20
Figure 31- Production Rate Control MPC [31].....	21
Figure 32- Production Rate Control MPC Model Identifier [31] .....	21

## REFERENCES

- [1] Cover Story – “DIGITAL TRANSFORMATION: Digital Twins Enable the Autonomous Paper Mill”; InTech Magazine; August 2021 | Vol 68, Issue 4; ISSN 0192-303X; © International Society of Automation (ISA). Awarded 2022 Excellence in Technical Presentation by the ISA Society Honors & Awards Committee at the November 2022 in Galveston Island, TX, USA
- [2] ISO TECHNICAL REPORT TR 24464 1st Edition, November 2020
- [3] ISO 23247; Automation Systems And Integration — Digital Twin Framework For Manufacturing
- [4] ISO/IEC TR 30172 ED1: Digital Twin - Use cases
- [5] ISO/IEC 30173 ED1: Digital Twin - Concepts and terminology
- [6] “The Start of Arauco’s MAPA Project”; Andritz Spectrum No. 39-/ 1-2019
- [7] “Eldorado Celulose: Self Driving Mill”; Andritz Spectrum, No. 36 / 2-2017
- [8] Daniel A. Silva, Minera Los Pelambres, Salamanca, Chile; Matt F. McGarry, Andritz Automation, Bellingham WA, USA; Andrés P. Rojas, Andritz Automation, Santiago, Chile; Rodrigo A. Gracia, Andritz Automation, Santiago, Chile; “Streamlining the Steps to Optimized Production: Project Process Modelling, Advanced Control, and Simulator Based Training for Optimized Operation – Case Studies”; Presented at CIM Conference, May 11-13, 2014, Vancouver, BC, Canada
- [9] “What Is a Digital Twin? 3 things you need to know”; <https://www.mathworks.com/discovery/digital-twin.html#digitaltwins-with-matlab-and-simulink>
- [10] Greg K. McMillan; “Understanding and Applying Simulation Fidelity to the Digital Twin”; July, 2018
- [11] André Luis Bogo & Patricia Nunes, Aracruz Celulose S.A., Espirito Santo, Brasil; Gabriel Hidalgo; IDEAS Simulation, Inc.; Vancouver, Canada; and Donald Wayne Herschmiller Veracel Celulose S.A., São Paulo, Brasil; “Aracruz Uses a Dynamic Simulator for Control System Staging and Operator Training”;
- [12] Brett W. Schug, Andritz Automation, Decatur, GA, United States. Michael R. Nees & Thomas V. Gamarano; Newmont Mining Corp., Greenwood Village, CO, United States. “Process Simulation for Improved Plant Design Through P&ID Validation”; Presented at SME 2012, Seattle, Washington, USA, February 22, 2012.
- [13] Lavigne, John R., “An Introduction to Paper Industry Instrumentation”, Revised Edition, Miller Freeman Publications, Inc., San Francisco, CA, 1977, ISBN: 0-87930-069-8.
- [14] Smook, Gary A., Author, M. J. Kocurek, Technical Editor; “Handbook for Pulp and Paper Technologists”, Joint Executive Committee of the Vocational Education Committees of the Pulp and Paper Industry, 1982, ISBN: 0-919893-00-7.
- [15] CyberBOILER™ Recovery Power Boiler Optimization System Functional Specification for Recovery Boiler At Mead Coated Board, Inc. Mahrt Mill Cottonton, Alabama By Orion CEM, Inc.
- [16] Danny Tandra, and Sandeep Shah; Clyde-Bergemann, Inc. Advanced Sootblowing Strategy Using Smart Sootblower”; Atlanta, GA
- [17] Dave Suplicki, Enertechnix, Maple Valley, WA; “Infrared Imaging Systems Waste to Energy Boilers”; <http://www.enertechnix.com/>
- [18] Sylvain Renaud and Bill Gough, Andritz Automation Solutions; "Model Based Predictive Adaptive Control of Pulp and Paper Mill Processes"; EXFOR Paperweek 2008 conference in Montreal
- [19] Harris Mayeaux and Kathy Hutson; "Advanced Controls at CCA Brewton Provide Stable Fiberline Operation"; Pulp & Paper Magazine; April 1, 1996
- [20] Van Fleet, Rick; Honeywell Process Solutions, Phoenix, AZ; “New Solution for Controlling Brown Stock Washers Utilizing Profit Controller Multivariable Predictive Control”; 92nd Annual EXFOR 2006 Technical Conference at the Palais de Congres in Montreal, PQ, Canada
- [21] Van Fleet, Rick; Honeywell Inc., Phoenix, AZ; “Bleach Plant Performance Enhanced Using Advanced Controls”; EXFOR 2005

- [22] Richard Van Fleet, BTG; "Control of the Extraction Stage Using the True Terminal pH"; PaperWeek Canada 2015 Bleaching Technical Track Presented at the Annual Conference of the Canadian Pulp and Paper Industry on Wednesday, February 4 at the Fairmont Queen Elizabeth Hotel in Montreal, PQ, Canada
- [23] Doug Reid; Nouryon; "pH in the BP Why It's Important - Part 1"; Originally presented on Tuesday, February 4 at the 2020 PaperWeek conference at The Fairmont The Queen Elizabeth Hotel in Montreal, Quebec, Canada
- [24] Rick Van Fleet, Honeywell International & Sandy BederMiller, BTG Americas; "Bleach Load: A New Inline Sensor Based Improvement for Bleach Plant Advanced Control"; PACWEST Conference Jasper, AB; June 1, 2012
- [25] Terence Blevins, Willy K. Wojsznis, & Mark Nixon; "Advanced Control Foundation: Tools, Techniques and Applications"; ISA; 2013; ISBN: 978-1-937560- 55-3
- [26] Timo Laurila; Metso; "Lime Kiln and Reconst -Tighten up the energy efficiency and availability of the lime kiln while improving reburned lime"; Originally presented at the Metso Automation USA Conference Series at the Red Lion Inn in Kelso, WA on November 16 & 17, 2010
- [27] Waller, Michael H.; Miami University; "Basis Weight Gauges - What's New?"; Waller, ISA Expo 2003
- [28] Stockford, David; OSIsoft; San Leandro, CA; "Real-time Performance Management in Pulp and Paper"; ISA Expo 2004
- [29] Marc Foulger and Denis Page, GLV Inc.; "Press Rebuilds for Improved Pressing Efficiency"; TAPPI/PIMA Papercon 2008 Conference; Dallas, TX
- [30] Kari Hilden, of PaperTech Inc.; "Improving Papermaking and Coating Efficiency with Web Inspection Cameras"; TAPPI/PIMA Papercon 2008 Conference; Dallas, TX
- [31] Michel R. Dion; Honeywell; "A practical approach for process control optimization during start-up Fiberline Process Optimization Pulp & Paper Industries"; Originally presented at the ISA@Montreal2018 Symposium at the Hyatt Regency Hotel on Tuesday, October 16, 2018